

Measurement of Load-Carrying Capacity of Lubricating Grease Using Macro-Tribometer mod. UMT-3 ASTM D2509-03

Summary of Test Method:

This test method uses the high load UMT-3 Block-on-Ring drive to determine the load-carrying capacity of lubricating greases. A steel test block is held under constant load against a continuously lubricated and rotating steel ring while the coefficient of friction is monitored. An increase in the coefficient of friction indicates the beginning of scoring of the test block and the breakdown of the lubricant film. Repeated tests with fresh blocks and rings at higher or lower loads are used to determine the maximum load that does not cause scoring and the minimum load that will cause scoring. In the initial test a load of 133.4 N is applied. If no scoring of the test block occurs, the load is increased by 44.5 N for the next test. The load is increased by 44.5 N in successive test until scoring observed. The load is then decreased by 22.2 N for the final test. If, on the other hand, scoring occurs on the initial test at 133.4 N, the load is decreased in the succeeding tests by 26.7 N increments until no scoring is observed. The load is then increased by 13.3 N for the final test.

In addition to the dynamic load and COF, the UMT allows for monitoring during the test the actual friction force, and depth of wear. Optionally, it can measure additional parameters of contact acoustic emission, temperature, and humidity.

Test Parameters

Load	Block Dimensions	Ring Dimensions	Temperature	Grease Feed Rate	Speed	Duration
Initial 133.4 N (see above)	L 19.05 mm W 12.32	Dia. 49.22 mm W 13.06 mm	25 ±6°C	45g/min.	123.71m/min. 800 rpm	Break-in 30s Test 10 min.

UMT Hardware Configuration:

- 4" Mounting Block N M30C366-2
- Model DFH-100 Dual Friction/Load Sensor range 10 to 1000 N
- Suspension for 100 kg Sensor PN AM30C110G-5
- Ball Holder for 1/4" Ball PN AM30B148A
- Steel Ball 1/4" PN BM110002
- Lower Block-on-Ring Drive mod. B33HE
- Liquid Container for Block-on-Ring Drive PN AM30C643-2
- Variable-Flow Peristaltic Pump
- Upper Specimen Test Block
- Lower Specimen Test Ring
- Optional Additional Sensors
 - mod. AE-5 Contact Acoustic Emission Detector
 - mod. HT-100 Humidity and Temperature Measurement & Recording
 - mod. ECR-1 Electrical Contact Resistance Measurement & Recording

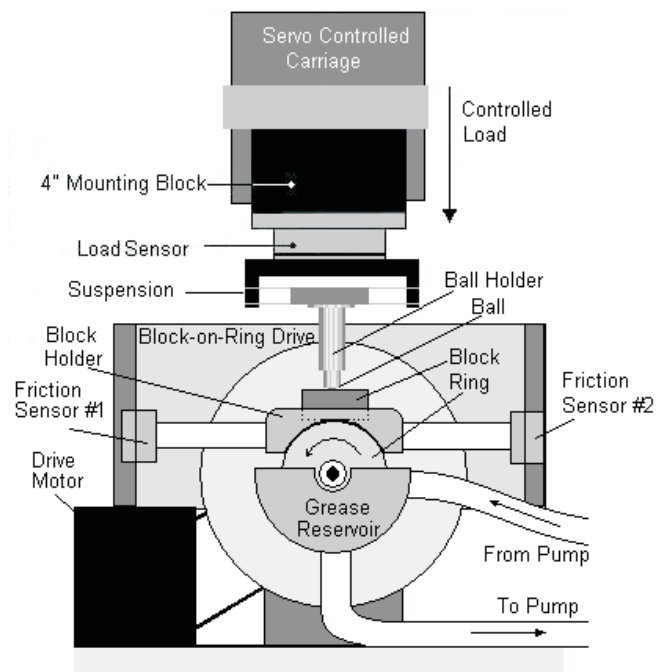

UMT Software Test Setup:

UMT Options File:

Load the options file which contains settings for the block-on-ring drive and the 1000 N force/load sensor.

Test Sequence:

The Test Sequence should consist of 3 steps.

Step 1 is for starting the grease pump and lubricating the ring.

General - *Controlled Carriage/Position, Incremental Carriage Displacement, Duration 10 sec.*

Carriage - *Start at current level, to 0, Working Velocity 0*

Spindle - *Velocity is 800 revs/min.*

Slider - *idle.*

Pump 1 - *Is used during this step*

Step 2 is a 30-sec. Break-in period

General - *Controlled Carriage/Load, Constant Force(Fz), Duration 30 sec.*

Carriage - *Force 133.4 N*

Spindle - *Velocity is 800 revs/min, Move-continuous, Counter Clockwise*

Slider - *idle.*

Pump 1 - *Is used during this step*

Step 3 is the 10 min. COF test period

General - *Controlled Carriage/Load, Constant Force(Fz), Duration 10 min.*

Carriage - *Force 133.4 N for first test. See text on previous page for force values for successive tests.*

Spindle - *Velocity is 800 revs/min, Move-continuous.*

Slider - *is idle.*

Pump 1 - *Is used during this step*

Data Collection:

The following should be checked under DataFile:

Fx – Friction Force

Fz – Normal Force

COF – Coefficient of Friction

T – Time

Z1 – Carriage Position (Used to determine Wear Depth)

AE input – Acoustic Emission (optional)

Rh input - Relative Humidity

Te input – Temperature (optional)

R1 - Electrical Resistance (optional)

Report:

Use the Viewer program to plot test results.

Select the parameters to be displayed by checking the appropriate box under Parameters on the Viewer screen.

